

REVISED 6/1/20

PRODUCT

OONA MINI BARE PENDANT
OONA MINI BARE 03

MATERIALS (FINISHES)

METAL (GOLDEN BRASS,
BLACKENED BRASS, SILVER,
BLACKENED SILVER)

GLASS (CLEAR)

WEIGHT

12.0 LBS

LAMPING

INCANDESCENT (QTY 3)
E12 BASE / T6 TUBULAR SHAPE
120V / 40 WATT MAX

CANOPY / CORD

5" ROUND CANOPY WITH
POSITIONABLE CEILING DROPS
6' CLOTH CORD

CERTIFICATIONS

ETL LISTED (120V, US/CANADA)

NOTES

OONA MINI IS AN ARTISAN-
CRAFTED HANGING PENDANT
FEATURING BLOWN GLASS AND
SOLID MACHINED HARDWARE.
OONA IS MEANT TO BE INSTALLED
BY A QUALIFIED AND LICENSED
ELECTRICIAN AND INSTALLATION
PROFESSIONAL.



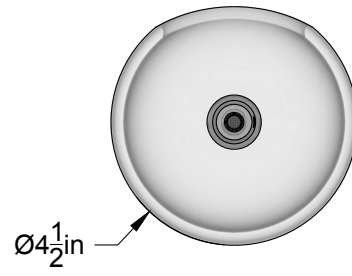

PLAN VIEW

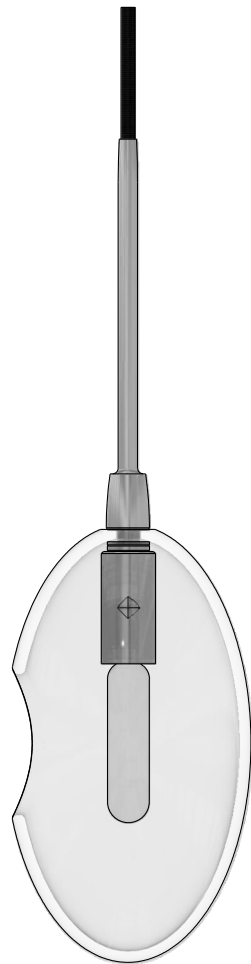

SIDE VIEW

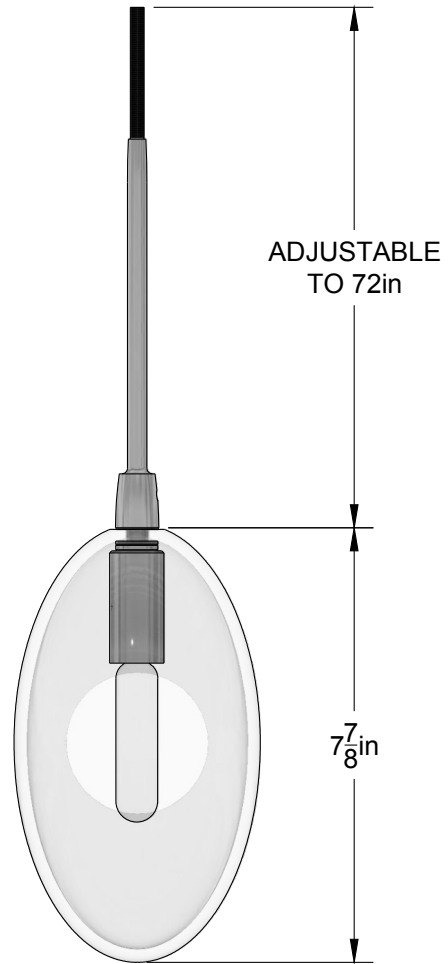

ELEVATION VIEW

© 2020, LAKE AND WELLS, LLC ALL RIGHTS RESERVED