

REVISED 5/1/20

PRODUCT

OONA BARE PENDANT
OONA BARE 01

MATERIALS (FINISHES)

METAL (GOLDEN BRASS,
BLACKENED BRASS, SILVER,
BLACKENED SILVER)

GLASS (CLEAR, SMOKE)

WEIGHT

9.0 LBS

LAMPING

INCANDESCENT (QTY 1)
E26 BASE / A23 SHAPE
120V / 40 WATT MAX

CANOPY / CORD

4.25" ROUND CANOPY
6' CLOTH CORD

CERTIFICATIONS

ETL LISTED (120V, US/CANADA)

NOTES

OONA IS AN ARTISAN-CRAFTED HANGING PENDANT FEATURING BLOWN GLASS AND SOLID MACHINED HARDWARE. OONA IS MEANT TO BE INSTALLED BY A QUALIFIED AND LICENSED ELECTRICIAN AND INSTALLATION PROFESSIONAL.



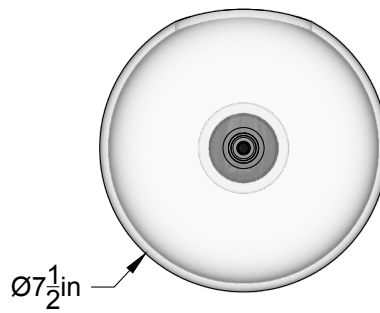

PLAN VIEW

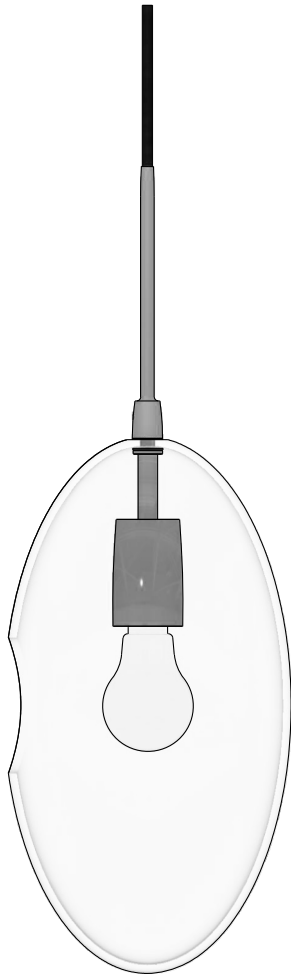

SIDE VIEW

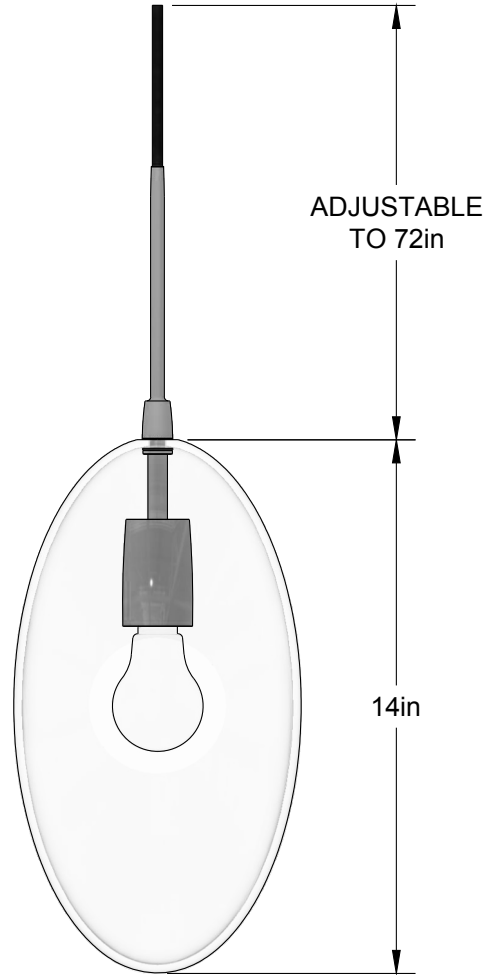

ELEVATION VIEW

© 2020, LAKE AND WELLS, LLC. ALL RIGHTS RESERVED