

REVISED 12/1/19

**PRODUCT**

OONA PENDANT  
OONA 05

**MATERIALS (FINISHES)**

METAL (GOLDEN BRASS,  
BLACKENED BRASS, SILVER,  
BLACKENED SILVER)

GLASS (CLEAR, SMOKE)

**WEIGHT**

47.5 LBS

**LAMPING**

INCANDESCENT (QTY 5)  
E26 BASE / A23 SHAPE  
120V / 40 WATT MAX

**CANOPY / CORD**

5" ROUND CANOPY WITH  
POSITIONABLE CEILING DROPS  
6" BLACK CORD

**CERTIFICATIONS**

ETL LISTED (120V, US/CANADA)

**NOTES**

OONA IS AN ARTISAN-CRAFTED HANGING PENDANT FEATURING BLOWN GLASS AND A FORMED METAL SHADE. OONA IS MEANT TO BE INSTALLED BY A QUALIFIED AND LICENSED ELECTRICIAN AND INSTALLATION PROFESSIONAL.



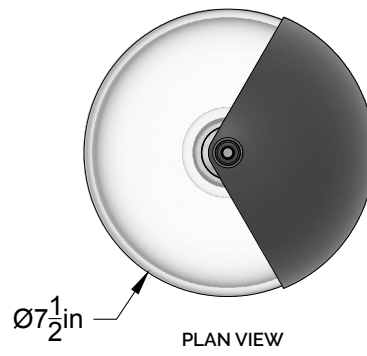

Ø7 1/2 in

PLAN VIEW

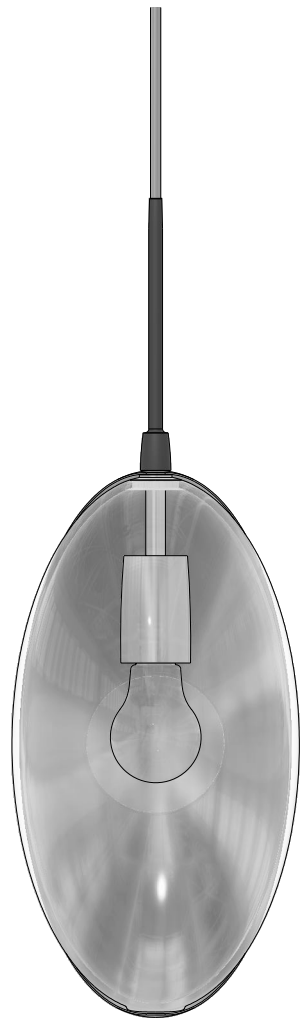

SIDE VIEW

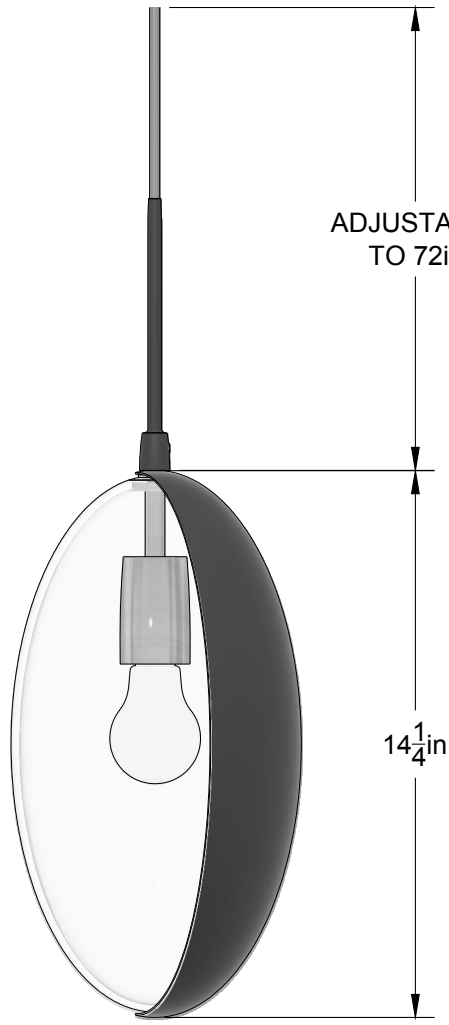

ADJUSTABLE  
TO 72 in

14 1/4 in

ELEVATION VIEW

© 2019, LAKE AND WELLS, LLC. ALL RIGHTS RESERVED