

REVISED 12/1/19

PRODUCT

OONA PENDANT
OONA 01

MATERIALS (FINISHES)

METAL (GOLDEN BRASS,
BLACKENED BRASS, SILVER,
BLACKENED SILVER)

GLASS (CLEAR, SMOKE)

WEIGHT

9.5 LBS

LAMPING

INCANDESCENT (QTY 1)
E26 BASE / A23 SHAPE
120V / 40 WATT MAX

CANOPY / CORD

4.25" ROUND CANOPY
6' BLACK CORD

CERTIFICATIONS

ETL LISTED (120V, US/CANADA)

NOTES

OONA IS AN ARTISAN-CRAFTED HANGING PENDANT FEATURING BLOWN GLASS AND A FORMED METAL SHADE. OONA IS MEANT TO BE INSTALLED BY A QUALIFIED AND LICENSED ELECTRICIAN AND INSTALLATION PROFESSIONAL.



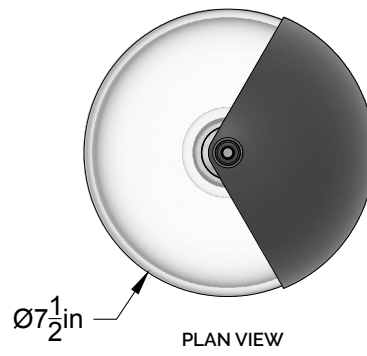

Ø7 1/2 in

PLAN VIEW

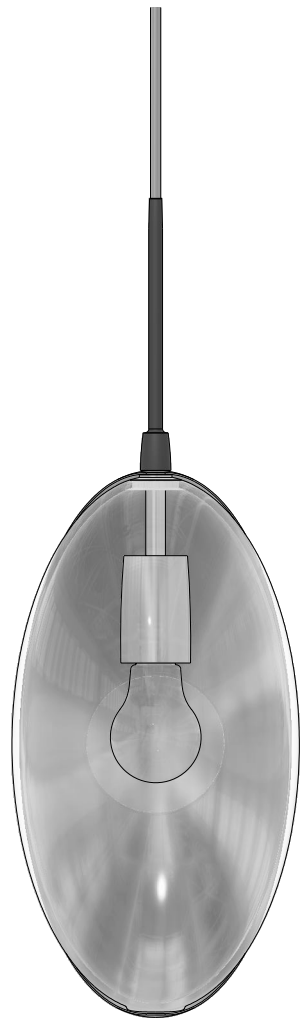

SIDE VIEW

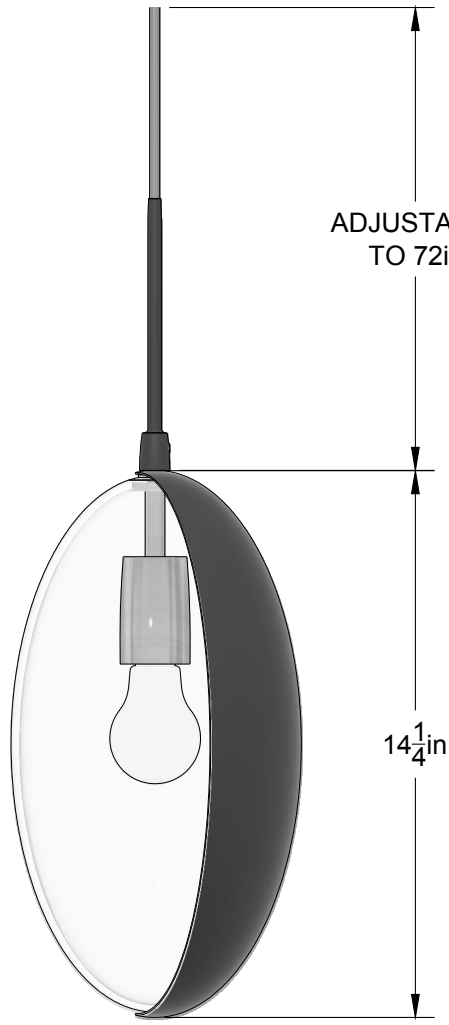

ADJUSTABLE
TO 72 in

14 1/4 in

ELEVATION VIEW

© 2019, LAKE AND WELLS, LLC. ALL RIGHTS RESERVED